

MINI SWING PISTON COMPRESSORS AND VACUUM PUMPS FOR AIR

DATA SHEET E 303



NPK 04 ... DC



NPK 04 ... DCB

Concept

The Swing Piston Pumps from KNF are based on a simple principal: As it rises and falls the piston tilts first to one side, then the other. The compression forces act along the axis of the connecting rod, so that there is no component of force acting against the cylinder wall to cause wear. Thanks to the sealing lip on the piston seal the swing piston pump runs dry, and 100% oil-free. They will evacuate, transfer and compress air without contamination.

For customers with unusual requirements the KNF Project Team produces specially tailored solutions. Use our experience to your advantage and talk to our applications engineers.

Features

- Uncontaminated flow**
No contamination of the air due to oil-free operation
- Maintenance-free**
- High level of flow-rate**
- Excellent price performance ratio**
- Very quiet and little vibration**
- Ready for installation**
- Can operate in any installed position**

Areas of use

The Mini Swing Piston Pumps offer a high level of performance despite their small size, as well as an excellent price performance ratio. They are used especially in the fields of medicine, environmental and production technology. These pumps are used for transferring, compressing and evacuation air, taking samples, evacuating vessels and compressing air in process systems and vessels.

PERFORMANCE DATA

| Type | Delivery (l/min) | Vacuum (mbar absolute) | atm. Press. | Pressure (bar g) | Weight (g) |
|---------------------|------------------|------------------------|-------------|------------------|------------|
| NPK 04 Vacuum DC | 3.3 | 300 | | | 200 |
| NPK 04 Pressure DC | 3.3 | | | 1.0 | 200 |
| NPK 04 Vacuum DCB | 3.3 | 300 | | | 280 |
| NPK 04 Pressure DCB | 3.3 | | | 1.0 | 280 |

NPK 04...DC

NPK 04...DCB

PERFORMANCE DATA

| Type Order code ²⁾ | Delivery at atm. pressure (l/min) ¹⁾ | Max. operating pressure (bar g) | Ultimate vacuum (mbar abs.) |
|----------------------------------|---|---------------------------------------|-----------------------------------|
| NPK 04 Vacuum DC | 3.3 | - | 300 |
| NPK 04 Pressure DC | 3.3 | 1.0 | - |

¹⁾ Litre at STP

²⁾ See also „MODEL CODES FOR EASY ORDERING“

PERFORMANCE DATA (Version with brushless dc motor)

| Type Order code ²⁾ | Delivery at atm. pressure (l/min) ¹⁾ | Max. operating pressure (bar) | Ultimate vacuum (mbar abs.) |
|----------------------------------|---|-------------------------------------|-----------------------------------|
| NPK 04 Vacuum DCB | 3.3 | - | 300 |
| NPK 04 Pressure DCB | 3.3 | 1.0 | - |

MOTOR DATA

| DC motor | 12 V | 24 V |
|----------|------|------|
| | | |

MOTOR DATA (Version with brushless dc motor)

| DC motor | 12 V | 24 V |
|----------|------|------|
| | | |

Dimensions mm (All dimensional tolerances conform to DIN ISO 2768-1, Tolerance Class V)

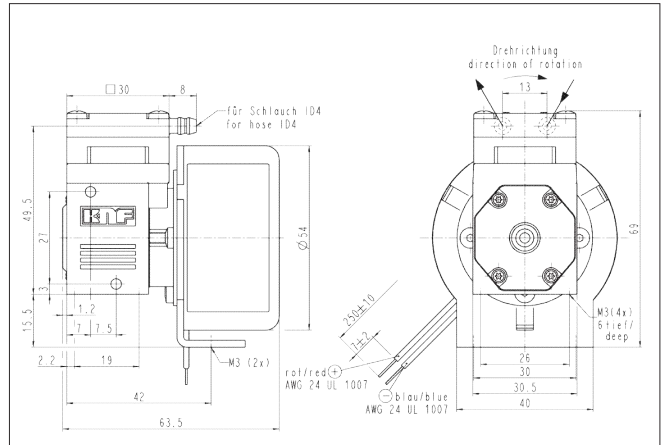
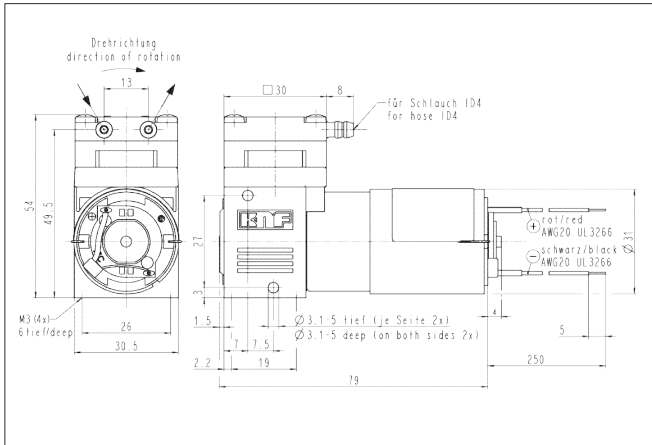

NPK 04 Vacuum

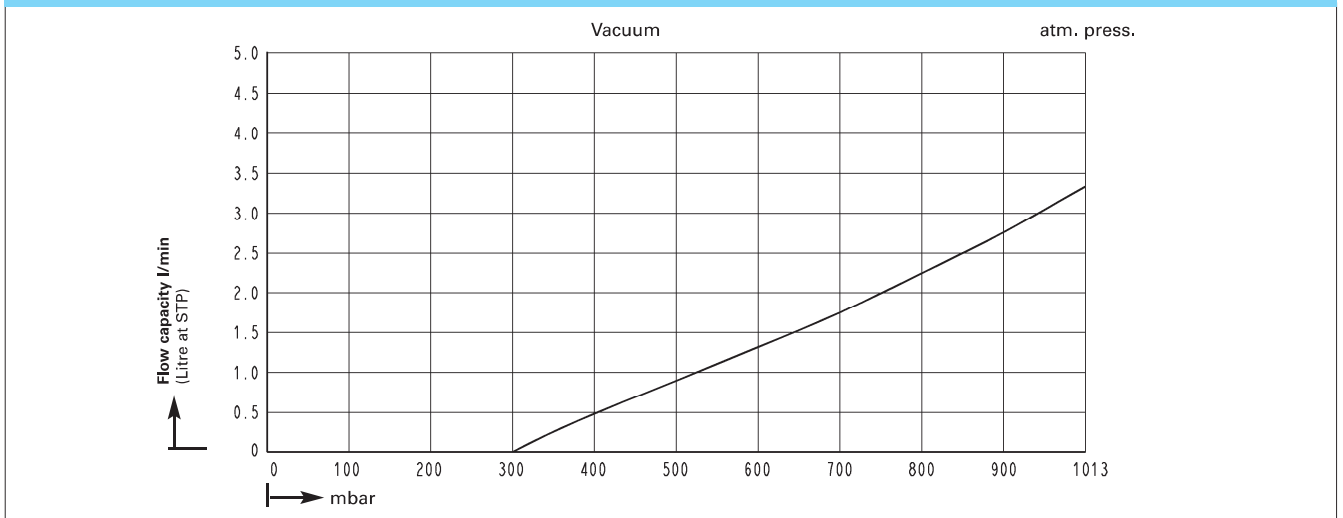

NPK 04 Pressure

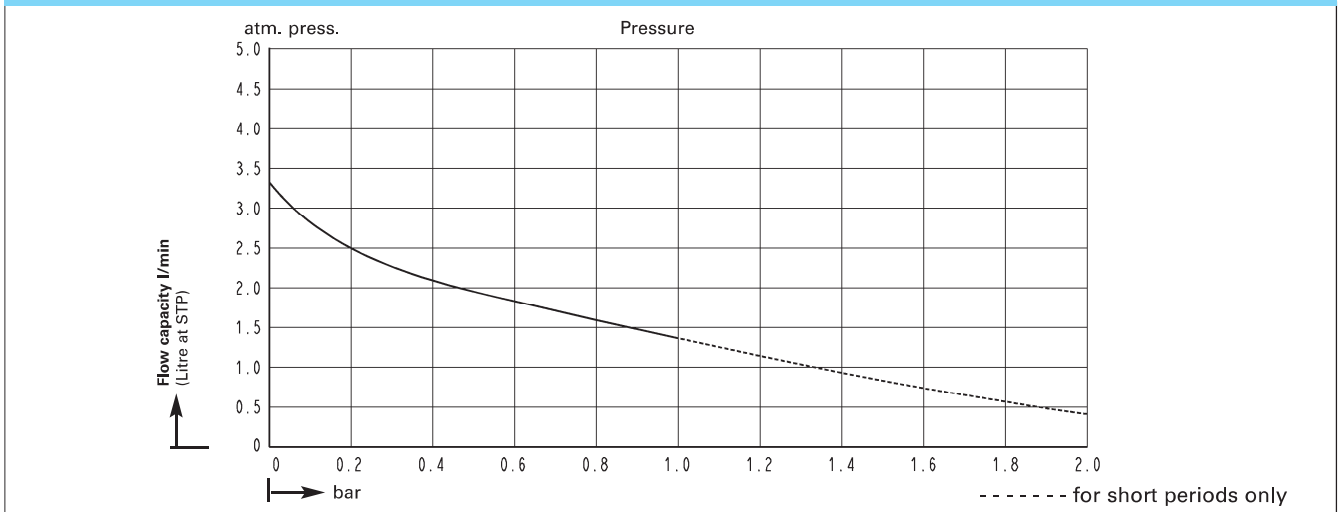

TECHNICAL INFORMATIONS

Pump down time for 5 l receiver

NPK 04 Vacuum

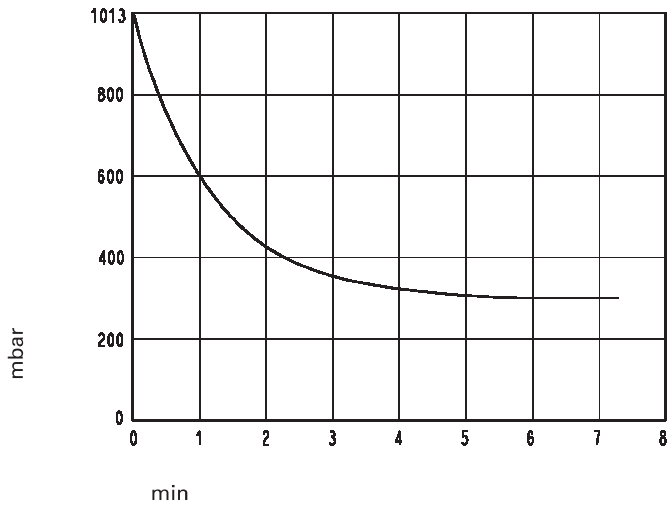

MODEL CODE FOR EASY ORDERING

The model code is identical to the order number. It is made up as follows:



- Base model
- Pump for vacuum or pressure
- DC motor or brushless DC motor
- Other motor data eg.: _____

In addition the motor data must be given in the purchase order. In our extensive program you are sure to find the pump you need for your particular application.

Accessories

| Description | Order No. | Details |
|-----------------|-----------|---------|
| Silencer/Filter | 024805 | |

Hints on function and installation: see back side

HINTS ON FUNCTION AND INSTALLATION

FUNCTION OF KNF SWING PISTON VACUUM PUMPS AND COMPRESSORS

As it rises and falls the piston tilts first to one side, then the other (see figure 1). Just as with the diaphragm pump, the compression forces act along the axis of the connecting rod, so that there is no component of force acting against the cylinder wall to cause wear. In contrast to the diaphragm pump (see figure 2), the swing piston pump has a sealing lip. Thanks to the sealing lip on the piston seal the swing piston pump runs dry, and 100% oil-free.

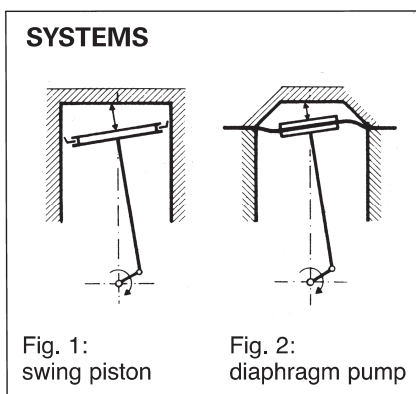

HINTS ON INSTALLATION AND OPERATION

- Range of use: Transferring air at temperatures between + 5 °C and + 40 °C
- Permissible ambient temperature: between + 5 °C and + 40 °C
- The standard pumps are not suitable for use in areas where there is a risk of explosion. In these cases there are other products in the KNF program - please ask us for details
- The pumps are not designed to start against pressure or vacuum; when a pump is switched on the pressure in the suction and pressure lines must be atmospheric. Pumps that start against pressure or vacuum are available on request
- To prevent the maximum operating pressure being exceeded, restriction or regulation of the air flow should only be carried out in the suction line

- Components connected to the pump must be designed to withstand the pneumatic performance of the pump
- Install the pump so that the fan can draw in sufficient cooling air
- Fit the pump at the highest point in the system, so that condensate cannot collect in the head of the pump - that prolongs working-life.

If you have any questions, please call our application engineers (see below for contact telephone number).

KNF - the competent partner for vacuum and compressor technology. Especially for unusual problems.

KNF Neuberger GmbH Diaphragm Pumps + Systems

Alter Weg 3
D-79112 Freiburg
Tel. ++49 (0)7664/5909-0
Fax ++49 (0)7664/5909-99
E-mail: info@knf.de
www.knf.de