

Standard KRX Series

特許 Patent

常见真空度 60kPa以下  
流量 135~1190L/min (50Hz)

Continuous operative Vacuum 60kPa or low  
Capacity 135~1190L/min (50Hz)



Photo:KRX6-P-V-03

特长

- 因为是无油式，所以在使用真空（真空规格）、排气（鼓风机规格）时，也不含有油分，不会对作业环境和产品（物体）造成油污。
- 运行声音低（由于去掉了使人感到厌烦的高周波音，即使在相同的dB值下，刺耳的声音也少）、寿命长。而且同时装备有真空压力表、调压控制阀。

Features

- No oil in either vacuum, pressure or combination application.
- Quiet operation.
- Long life.
- Gauge and controller equipment standard.
- Dependable proven Design.

规格

型式 Model	设计排气量 Designed pumping capacity (L/min)(※1)		到达真空度 Ultimate vacuum (kPa以上) (※2) (Over:kPa)	常用真空度 Continuous operative vacuum (kPa以下) (※3) (Under:kPa)	常用排气压力 Continuous operative pressure (kPa以下) (※3) (Under:kPa)	配管接口 Suction, exhaust port diameter
	50Hz	60Hz	50Hz			

电源 Motor voltage	三相 Three phase						装载电机 (kw) Motor	质量(kg) Mass		
	单相 Single phase		三相 Three phase					单相 Single phase	三相 Three phase	
	100V	220V	200V	380V	400V	415V				440V
			50/60Hz				50Hz	60Hz		

KRX1-P-□-□

V-01	135	155	78	60	-	Rc3/4	○	○	-	-	-	-	-	0.2	16.5	-
V-03	135	155	78	60	-	Rc3/4	-	-	○	○	○	○	○	0.2	-	15
B-01	135	155	-	-	60	Rc3/4	○	○	-	-	-	-	-	0.2	16.5	-
B-03	135	155	-	-	60	Rc3/4	-	-	○	○	○	○	○	0.2	-	15
VB-01	135	155	-	V(吸气)+B(排气)<60kPa		Rc3/4	○	○	-	-	-	-	-	0.2	16.5	-
VB-03	135	155	-	V(吸气)+B(排气)<60kPa		Rc3/4	-	-	○	○	○	○	○	0.2	-	15

KRX3-P-□-□

V-01	235	280	84	60	-	Rc3/4	○	○	-	-	-	-	-	0.37	25.5	-
V-03	235	280	84	60	-	Rc3/4	-	-	○	○	○	○	○	0.37	-	21
B-01	235	280	-	-	60	Rc3/4	○	○	-	-	-	-	-	0.37	25.5	-
B-03	235	280	-	-	60	Rc3/4	-	-	○	○	○	○	○	0.37	-	21
VB-01	235	280	-	V(吸气)+B(排气)<60kPa		Rc3/4	○	○	-	-	-	-	-	0.37	25.5	-
VB-03	235	280	-	V(吸气)+B(排气)<60kPa		Rc3/4	-	-	○	○	○	○	○	0.37	-	21

KRX5-P-□-□

V-01	405	480	86	60	-	Rc3/4	○	○	-	-	-	-	-	0.75	34	-
V-03	405	480	86	60	-	Rc3/4	-	-	○	○	○	○	○	0.75	-	33
B-01	405	480	-	-	60	Rc3/4	○	○	-	-	-	-	-	0.75	34	-
B-03	405	480	-	-	60	Rc3/4	-	-	○	○	○	○	○	0.75	-	33
VB-01	405	480	-	V(吸气)+B(排气)<60kPa		Rc3/4	○	○	-	-	-	-	-	0.75	34	-
VB-03	405	480	-	V(吸气)+B(排气)<60kPa		Rc3/4	-	-	○	○	○	○	○	0.75	-	33

KRX6-P-□-□

V-03	575	685	86	60	-	Rc3/4	-	-	○	○	○	○	○	1.5	-	50
B-03	575	685	-	-	60	Rc3/4	-	-	○	○	○	○	○	1.5	-	50
VB-03	575	685	-	V(吸气)+B(排气)<60kPa		Rc3/4	-	-	○	○	○	○	○	1.5	-	50

KRX7A-P-□-□

V-03	1190	-	90	60	-	Rc1	-	-	○	○	○	○	-	2.2	-	79
B-03	1190	-	-	-	60	Rc1	-	-	○	○	○	○	-	2.2	-	79
VB-03	1190	-	-	V(吸气)+B(排气)<60kPa		Rc1	-	-	○	○	○	○	-	2.2	-	79

- ※1设计排气量：由容积所计算出的理论值。实际流量参考性能实测数据。
- ※2泵所到达最高真空点在实际不能使用时。只是为了机种选定计算而使用。
- ※3可能使用的真空度（排气压力）范围。
- ※KRX7A泵不能用于60Hz区域。当在60Hz区域使用时请与代理商或厂家联系。
- ※也有各机种的单体泵（只有泵头）。
- ※使用环境（吸入空气）条件：温度：0~40℃、湿度：通常湿度（65±20%）。
- ※电源电压的允许波动范围为额定电压±10%。
- ※请设置过负荷保护器（热敏继电器等）。
- ※设定值请以电机标牌上记载的额定电流值为标准。

- ※1 Design displacement: Logic value calculated from the cubic Volume. Regarding the actual flow rate, refer to the actual Measurement data of performances.
- ※2 It is not allowable to use it at the maximum vacuum reaching point of the pump. Use it for model selection calculations.
- ※3. Usable range of the degree of vacuum (exhaust pressure) range.
- ※ The pump of the KRX7A series models is unusable in the 60HZ range. Please ask for ORION dealers or manufactures if it is used in this condition. And various independent pumps are also available.
- ※ As the intake gas, use clean air of ordinary temperature and ordinary humidity whenever possible. [Using environmental conditions (intake air) should be 0~40℃ in the temperature and 65±20% in the humidity].
- ※ The allowable variation range of the supply voltage should be rated voltage (10%).
- ※ Install an overload protector (thermal relays, etc.). setting value; Use the rated current value being indicated on the specification plate of the motor as target value.

性能实测数据 (- 50Hz)

Performance data

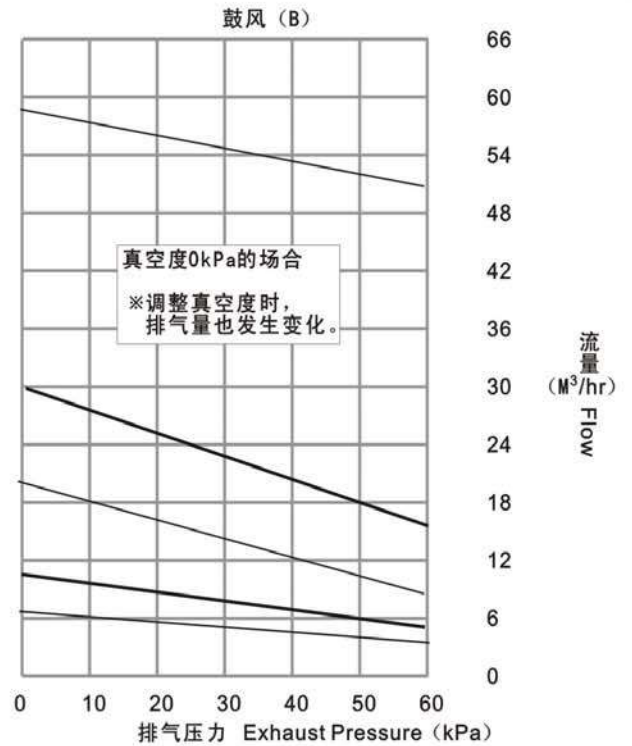
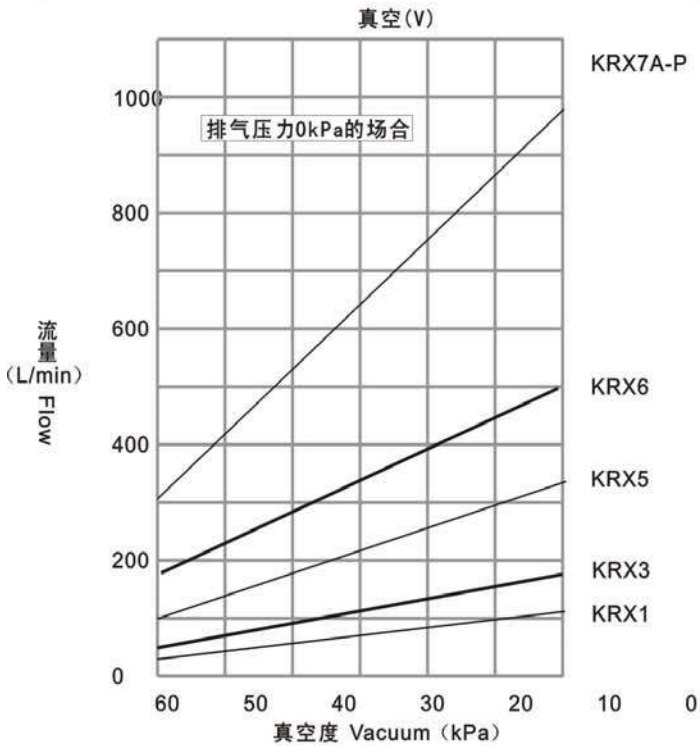

外形尺寸 (尺寸单位: mm)

Outer dimensions (Unit:mm)

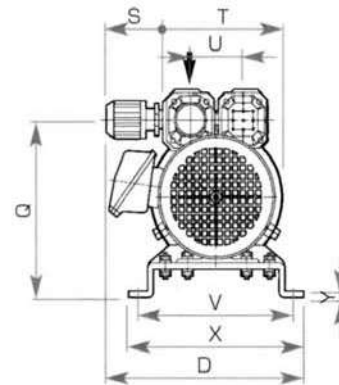
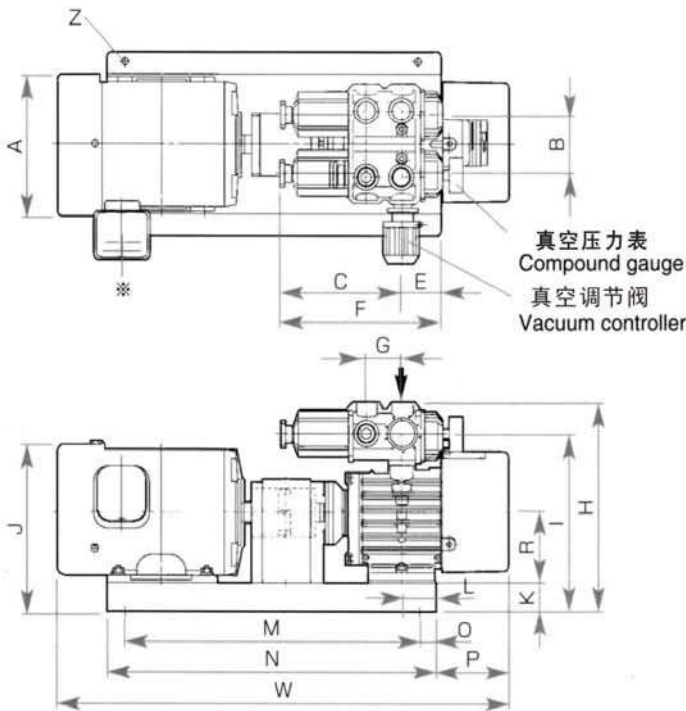

型式	H	D	W	A	B	C	E	F	G	I	J	K	L
KRX1-P	227(234)	245	372(379)	φ119(φ131)		135	42	177		187(195)	158(212)		40
KRX3-P	248(257)	270	468(482)	φ144(φ137)	80	135	42	177	92	208(217)	176(172)	32	30
KRX5-P	250		542(548)	φ162(φ150)		135	42	177		210	193(187)		45
KRX6-P	273	276	646	φ186		173	54	227		233	222	38	50
KRX7A-P	325	379	739	φ207	100	197.5	24	221.5	70	270	241.5	38	4

型式	M	N	O	P	Q	R	S	T	U	V	X	Y	Z
KRX1-P	240	300		44	189.5(197.5)	63(71)	63			186	210	3.2	
KRX3-P	304	364	30	77	210.5(219.5)	71							
KRX5-P	340	402	31	83	212.5	80	78	154	90	205	230	4.5	4-φ9
KRX6-P	420	470	25	102	235.5	90				220	242		
KRX7A-P	430	530	50	185.5	270	100	86	200	110	250	280	4.5	4-φ12

※( )内尺寸表示带单相电机。  
※图表示真空规格。